

Three-storey apartment house

Total area, m2	688,30
Total cost with assembly	€ 558 452
Price per m2	€ 811

Included in the price: Building, windows and exterior doors, shutters, installation, exterior finishing, and roofing.

Not included: Foundation, delivery, crane and scaffolding, interior finishing, electrical wiring, water supply, sewerage, heating and air conditioning.

1st floor: 7 apartments with living room studio and bathroom. 1 apartment with a bedroom, living room studio and bathroom.

2nd floor: 7 apartments with living room studio and bathroom. 1 apartment with a bedroom, living room studio and bathroom.

3rd floor: 5 apartments with living room studio and bathroom. 1 apartment with a bedroom, living room studio and bathroom.



1 floor plan.
1:100 (A-3)



2 floor plan.
1:100 (A-3)



3 floor plan.
1:100 (A-3)

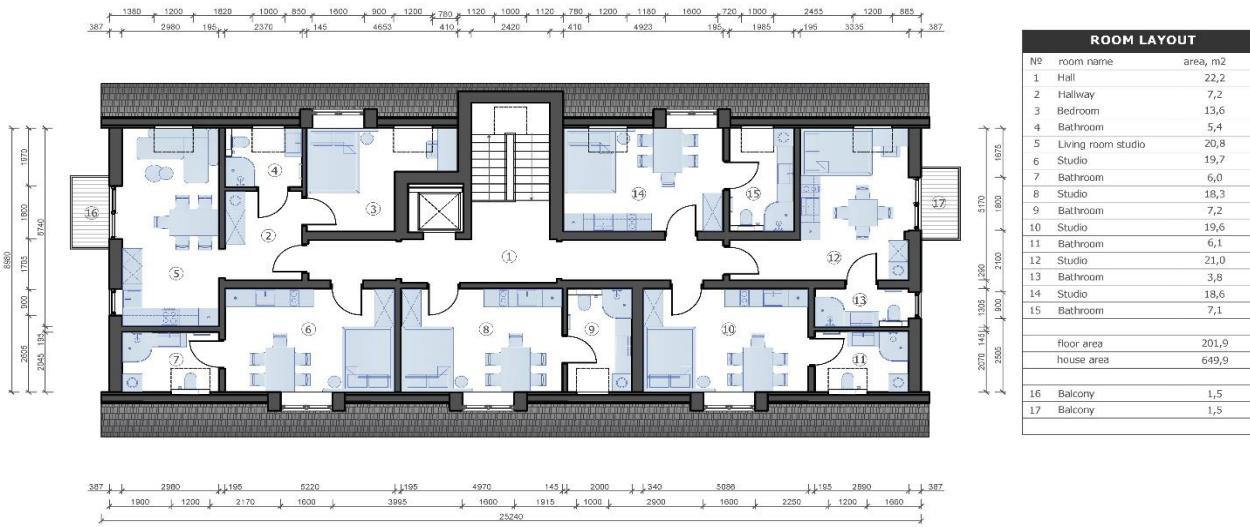

Three-storey apartment house

Timber frame-panel construction set

Thermal transmission losses through the external structures of the house (external walls, roof, windows and doors) comply with KfW Effizienzhaus 40+.

							0,18
Energy efficiency U, W/m²K, max.							
Internal house area, m²							688,3
	Thickness, mm	U, W/m ² K	Area, m ² / Number, pcs	Price, m ² /price, pcs			Total
Exterior walls, plaster, painting:							
IZOVAT basalt insulation, OSB 3, beams, plasterboard, finishing	387	0,11	348,57	€ 152	€		53 134
Internal walls:							
IZOVAT basalt insulation, OSB 3, beams, plasterboard	244	0,19	606,34	€ 132	€		80 240
Partitions:							
IZOVAT basalt insulation, OSB 3, beams, plasterboard	144	0,36	155,83	€ 104	€		16 266
Ceilings:							
IZOVAT basalt insulation, OSB 3, beams, plasterboard	310	0,15	710,77	€ 148	€		105 355
Pitched roof:							
IZOVAT basalt insulation, OSB 3, beams, plasterboard	413	0,11	428,70	€ 150	€		64 325
Windows, roller shutters:							
Rehau Synego profile Automatic overhead window slides	-	0,68	110,60	€ 597	€		65 995
Facade and roof finishing materials:							
decorative facade plaster, facade paint, ceramic tiles, drainage system			688,30	€ 48	€		32 723
Assembly of the house frame			688,30	€ 85	€		58 506
Exterior finishing of the facade and roof			688,30	€ 119	€		81 908
Total cost with assembly				€			558 452
Price per m² of internal area				€			811

Exterior walls - plaster facade

Thickness, mm	386,60
Energy efficiency U, W/m ² K	0,11
Area, m ²	459,17
Openings, m ²	110,60
Calculation area, m²	348,57

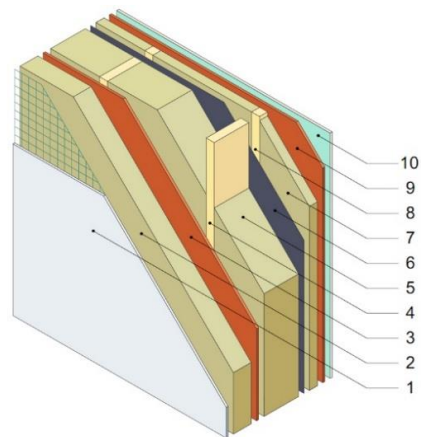
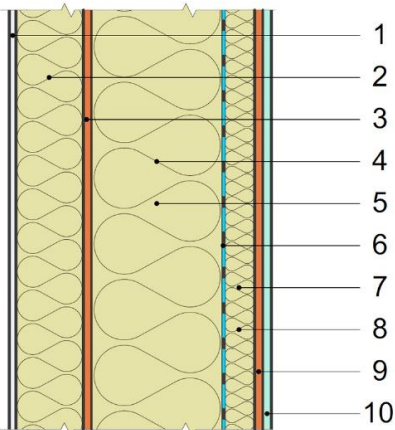

Materials	Thickness, mm
Ceresit CT 85 FLEX Mortar facade plaster	10,00
Ceresit CT325 Glass-Fibre Mesh 160 g /m ²	1
Basalt insulation material IZOVAT, 135 kg/m ³ 100 mm	2
OSB 3 Egger 12 mm	3
Beam 45*195 mm C24 CE	4
Basalt insulation material IZOVAT, 40 kg/m ³ 100 mm	5
Basalt insulation material IZOVAT, 40 kg/m ³ 100 mm	195,00
Vapour barrier	6
Basalt insulation material IZOVAT, 40 kg/m ³ 50 mm	7
Lath 45x45 mm	8
OSB 3 Egger 12 mm	9
Plasterboard	10
Total thickness, mm	386,60
Total cost	€ 53 134,02
Price per m² calculated area	€ 152,44

Inner walls

Thickness, mm	244,20
Energy efficiency U, W/m ² K	0,19
Area, m ²	659,26
Openings, m ²	52,92
Calculation area, m²	606,34

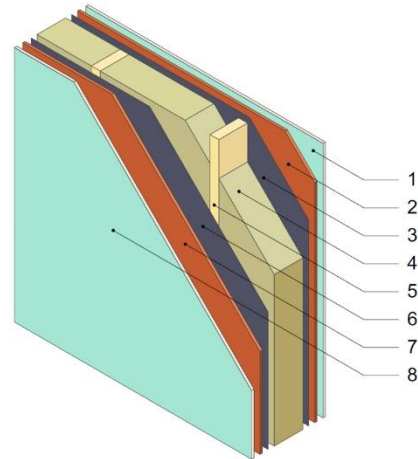
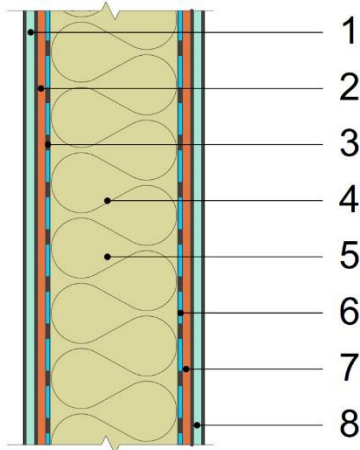

Materials	Thickness, mm
Plasterboard	1 12,50
OSB 3 Egger 12 mm	2 12,00
Vapour barrier	3 0,10
Beam 45*95 mm C24 CE	4
Basalt insulation material IZOVAT, 40 kg/m ³ 100 mm	5 195,00
Basalt insulation material IZOVAT, 40 kg/m ³ 100 mm	
Vapour barrier	6 0,10
OSB 3 Egger 12 mm	7 12,00
Plasterboard	8 12,50
Total thickness, mm	244,20
Total cost	€ 80 239,58
Price per m² calculated area	€ 132,34

Partitions

Thickness, mm	144,00
Energy efficiency index, U, W/m ² K	0,36
Area, m ²	195,52
Openings, m ²	39,69
Calculation area, m²	155,83

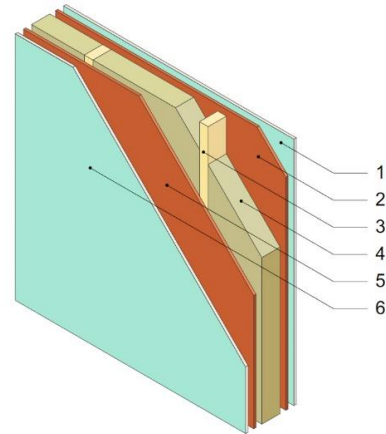
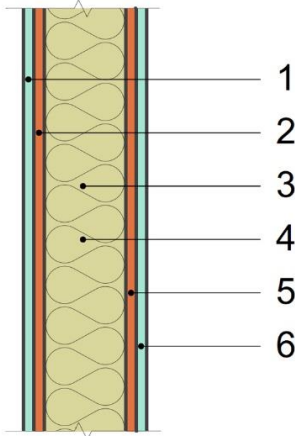

Materials	Thickness, mm
Plasterboard	1 12,50
OSB 3 Egger 12 mm	2 12,00
Beam 45*95 mm C24 CE	3 95,00
Basalt insulation material IZOVAT, 40 kg/m ³ 100 mm	4
OSB 3 Egger 12 mm	5 12,00
Plasterboard	6 12,50
Total thickness, mm	144,00
Total cost	€ 16 266,40
Price per m² calculated area	€ 104,39

Ceilings

Thickness, mm	309,60
Energy efficiency index, U, W/m ² K	0,15
Area, m ²	736,71
Openings, m ²	25,94
Calculation area, m²	710,77

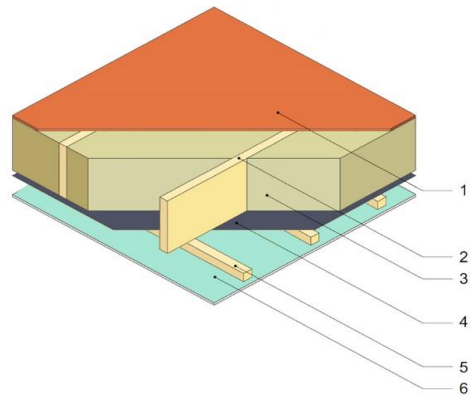
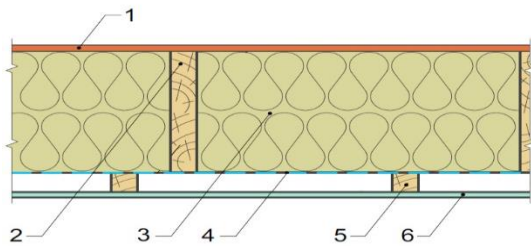

Materials	Thickness, mm	
OSB 3 Egger 22 mm	1	22,00
Glued beam 45*2*245 mm C24 CE	2	
Basalt insulation material IZOVAT, 40 kg/m3 100 mm	3	245,00
Basalt insulation material IZOVAT, 40 kg/m3 100 mm		
Basalt insulation material IZOVAT, 40 kg/m3 50 mm		
SIGA MajRex vapour barrier	4	0,10
Lath 30x45 mm	5	30,00
Knauf plasterboard	6	12,50
Total thickness, mm		309,60
Total cost	€	105 355,22
Price per m² calculated area	€	148,23

Pitched roof

Thickness, mm	412,70
Energy efficiency index, U, W/m ² K	0,11
Calculation area, m²	428,70

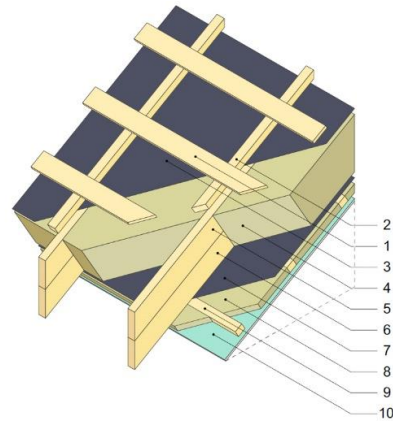
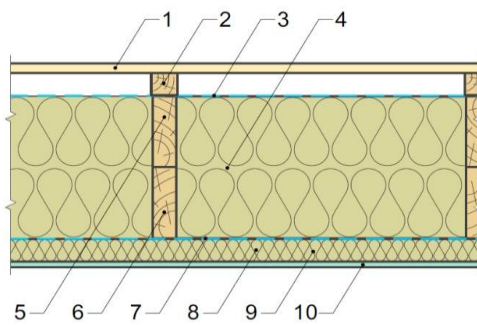

Materials	Thickness, mm	
Lath 20x100 mm	1	20,00
Lath 45x50 mm	2	45,00
Super defusion membrane	4	0,10
Beam 45*145 mm C24 CE	5	
Beam 45*145 mm C24 CE	6	
Basalt insulation material IZOVAT, 40 kg/m ³ 100 mm		290,00
Basalt insulation material IZOVAT, 40 kg/m ³ 100 mm	7	
Basalt insulation material IZOVAT, 40 kg/m ³ 100 mm		
Vapour barrier	8	0,10
Basalt insulation material IZOVAT, 40 kg/m ³ 50 mm	9	45,00
Lath 45x50 mm	10	
Plasterboard	11	12,50
Total thickness, mm		412,70
Total cost	€	64 325,24
Price per m² calculated area	€	150,05

Windows

Calculation area, m²

110,60



Materials

Rehau Synego window profile (installation in wall panels included)

Profile thickness 80mm (depends on window openings)	€	45 383,67
Glazing 4i-16ArTep-4-16ArTep-4i, 44mm Ug=0.57 W/m ² K		
Fittings MACO, G-U		
Alenor sealing tapes	€	2 362,06
Aluminium window sills	€	1 242,65
Automatic window slides, anthracite colour	€	17 006,83
Average heat losses of window constructions Uw, W/m ² K 0.68		
Total cost	€	65 995,21
Price per m² calculated area	€	596,70

Facade and roof finishing

Calculated facade area, m ²	453,14
Calculated roof area, m ²	428,70



Materials		
Decorative facade plaster	€	10 645,34
Facade paint	€	1 935,52
Ceramic roof tiles (set)	€	14 648,91
Drainage system	€	5 493,34
Total cost	€	32 723,10