

Three-storey apartment house

Total area, m2	392,50
Total cost with assembly	€ 316 970
Price per m2	€ 808

Included in the price: Building, windows and exterior doors, shutters, installation, exterior finishing and roofing.

Not included: Foundation, delivery, crane and scaffolding, interior finishing, electrical wiring, water supply, sewerage, heating and air conditioning.

1st floor: 2 apartments with a bedroom and living room studio.

2nd floor: 2 apartments. 1x with 2 bedrooms, living room studio and 1x with 1 bedroom and studio.

3rd floor: 2 apartments with a bedroom, living room studio and a terrace.



1st floor plan.
1:75 (A-3)

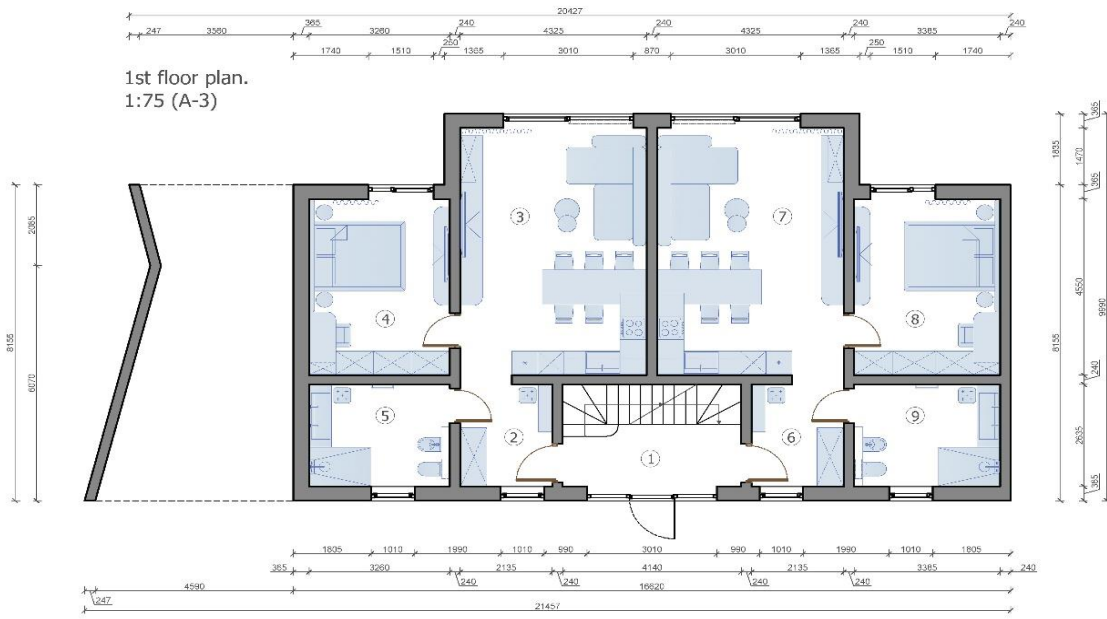

ROOM LAYOUT					
Nº	room name	area, m ²	Nº	room name	area, m ²
1	Hall	6,6	6	Hallway	5,6
2	Hallway	5,6	7	Living room studio	27,9
3	Living room studio	27,9	8	Bedroom	15,4
4	Bedroom	14,8	9	Bathroom	8,9
5	Bathroom	8,6			
				floor area	121,3
				total area	392,5

2nd floor plan.
1:75 (A-3)

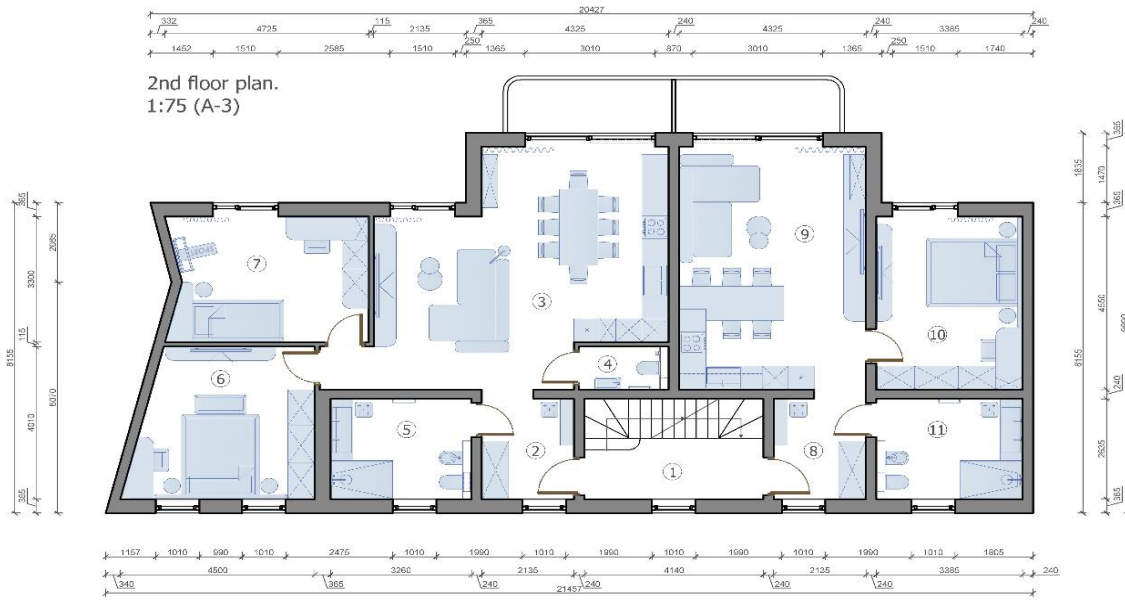

ROOM LAYOUT					
Nº	room name	area, m ²	Nº	room name	area, m ²
1	Hall	6,6	7	Children's room	14,9
2	Hallway	5,6	8	Hallway	5,6
3	Living room studio	38,0	9	Living room studio	27,9
4	Bathroom	2,4	10	Bedroom	15,4
5	Bathroom	8,6	11	Bathroom	8,9
6	Bedroom	16,0			
				floor area	149,9
				total area	392,5



Three-storey apartment house

Timber frame-panel construction set

Thermal transmission losses through the external structures of the house (external walls, roof, windows and doors) comply with KfW Effizienzhaus 40+.

							0,17
Energy efficiency U, W/m ² K, max.							
Internal house area, m ²							392,5
	Thickness, mm	U, W/m ² K	Area, m ² / Number, pcs	Price, m ² /price, pcs	Total		
Exterior walls, plaster, painting:							
IZOVAT basalt insulation, OSB 3, beams, plasterboard, finishing	387	0,11	345,23	€ 152	€	€	52 626
Internal walls:							
IZOVAT basalt insulation, OSB 3, beams, plasterboard	244	0,19	233,42	€ 132	€	€	30 889
Partitions:							
IZOVAT basalt insulation, OSB 3, beams, plasterboard	144	0,36	90,13	€ 104	€	€	9 408
Ceilings:							
IZOVAT basalt insulation, OSB 3, beams, plasterboard	310	0,15	335,68	€ 148	€	€	49 757
Pitched roof:							
IZOVAT basalt insulation, OSB 3, beams, plasterboard	413	0,11	176,76	€ 150	€	€	26 523
Flat roof:							
IZOVAT basalt insulation, OSB 3, beams, plasterboard	413	0,10	35,05	€ 165	€	€	5 783
Windows, roller shutters:							
Rehau Synego profile Automatic overhead window slides	-	0,68	66,20	€ 597	€	€	39 502
Facade and roof finishing materials:							
decorative facade plaster, facade paint, ceramic tiles, drainage system			392,50	€ 57	€	€	22 412
Assembly of the house frame			392,50	€ 85	€	€	33 363
Exterior finishing of the facade and roof			392,50	€ 119	€	€	46 708
Total cost with assembly				€			316 970
Price per m² of internal area				€			808

Exterior walls - plaster facade

Thickness, mm	386,60
Energy efficiency U, W/m ² K	0,11
Area, m ²	408,80
Openings, m ²	63,57
Calculation area, m²	345,23

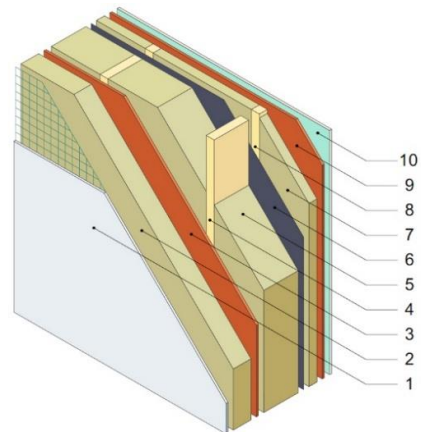
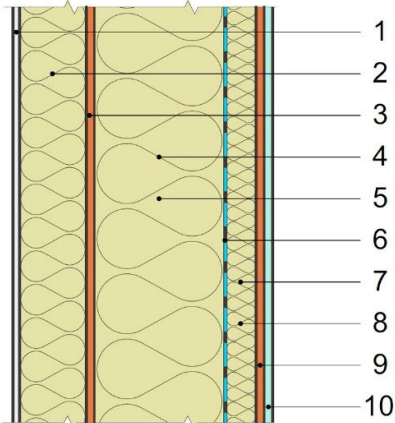

Materials	Thickness, mm
Ceresit CT 85 FLEX Mortar facade plaster	10,00
Ceresit CT325 Glass-Fibre Mesh 160 g /m ²	1
Basalt insulation material IZOVAT, 135 kg/m ³ 100 mm	2
OSB 3 Egger 12 mm	3
Beam 45*195 mm C24 CE	4
Basalt insulation material IZOVAT, 40 kg/m ³ 100 mm	5
Basalt insulation material IZOVAT, 40 kg/m ³ 100 mm	195,00
Vapour barrier	6
Basalt insulation material IZOVAT, 40 kg/m ³ 50 mm	7
Lath 45x45 mm	8
OSB 3 Egger 12 mm	9
Plasterboard	10
Total thickness, mm	386,60
Total cost	€ 52 625,83
Price per m² calculated area	€ 152,44

Inner walls

Thickness, mm	244,20
Energy efficiency U, W/m ² K	0,19
Area, m ²	265,55
Openings, m ²	32,13
Calculation area, m²	233,42

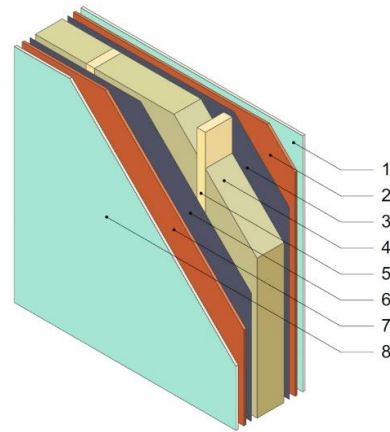
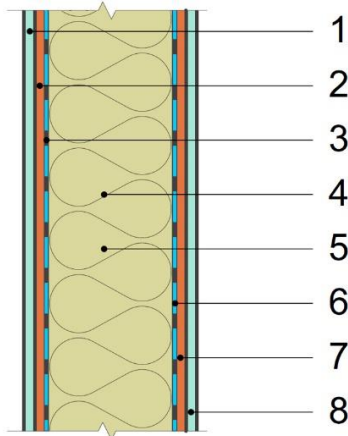

Materials	Thickness, mm
Plasterboard	1 12,50
OSB 3 Egger 12 mm	2 12,00
Vapour barrier	3 0,10
Beam 45*95 mm C24 CE	4
Basalt insulation material IZOVAT, 40 kg/m ³ 100 mm	5 195,00
Basalt insulation material IZOVAT, 40 kg/m ³ 100 mm	
Vapour barrier	6 0,10
OSB 3 Egger 12 mm	7 12,00
Plasterboard	8 12,50
Total thickness, mm	244,20
Total cost	€ 30 889,02
Price per m² calculated area	€ 132,34

Partitions

Thickness, mm	144,00
Energy efficiency index, U, W/m ² K	0,36
Area, m ²	101,47
Openings, m ²	11,34
Calculation area, m²	90,13

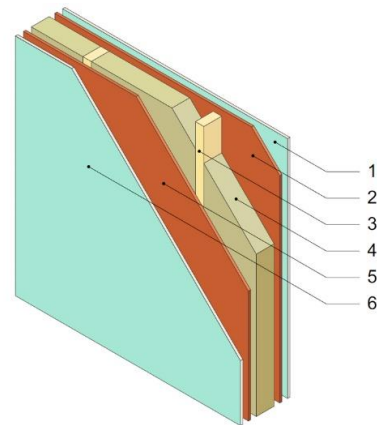
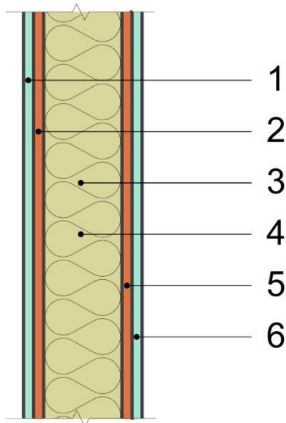

Materials	Thickness, mm	
Plasterboard	1	12,50
OSB 3 Egger 12 mm	2	12,00
Beam 45*95 mm C24 CE	3	95,00
Basalt insulation material IZOVAT, 40 kg/m ³ 100 mm	4	
OSB 3 Egger 12 mm	5	12,00
Plasterboard	6	12,50
Total thickness, mm		144,00
Total cost	€	9 407,85
Price per m² calculated area	€	104,39

Ceilings

Thickness, mm	309,60
Energy efficiency index, U, W/m ² K	0,15
Area, m ²	345,28
Openings, m ²	9,60
Calculation area, m²	335,68

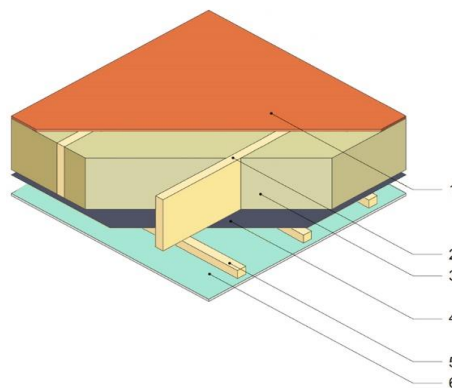
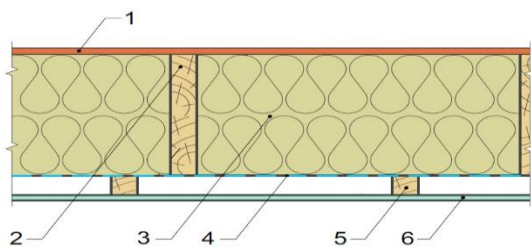

Materials	Thickness, mm	
OSB 3 Egger 22 mm	1	22,00
Glued beam 45*2*245 mm C24 CE	2	
Basalt insulation material IZOVAT, 40 kg/m3 100 mm		245,00
Basalt insulation material IZOVAT, 40 kg/m3 100 mm	3	
Basalt insulation material IZOVAT, 40 kg/m3 50 mm		
SIGA MajRex vapour barrier	4	0,10
Lath 30x45 mm	5	30,00
Knauf plasterboard	6	12,50
Total thickness, mm		309,60
Total cost	€	49 757,15
Price per m² calculated area	€	148,23

Pitched roof

Thickness, mm	412,70
Energy efficiency index, U, W/m ² K	0,11
Calculation area, m²	176,76

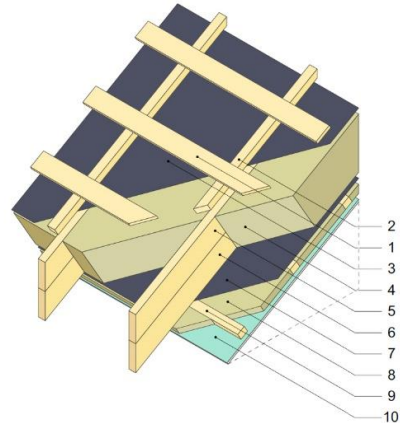
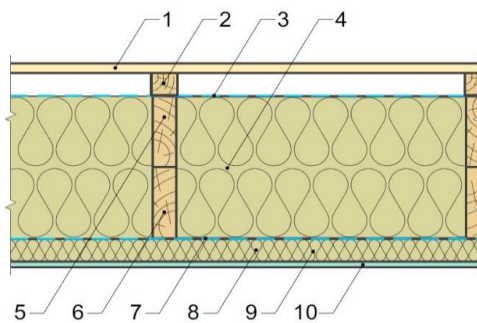

Materials	Thickness, mm	
Lath 20x100 mm	1	20,00
Lath 45x50 mm	2	45,00
Super defusion membrane	4	0,10
Beam 45*145 mm C24 CE	5	
Beam 45*145 mm C24 CE	6	
Basalt insulation material IZOVAT, 40 kg/m ³ 100 mm		290,00
Basalt insulation material IZOVAT, 40 kg/m ³ 100 mm	7	
Basalt insulation material IZOVAT, 40 kg/m ³ 100 mm		
Vapour barrier	8	0,10
Basalt insulation material IZOVAT, 40 kg/m ³ 50 mm	9	45,00
Lath 45x50 mm	10	
Plasterboard	11	12,50
Total thickness, mm		412,70
Total cost	€	26 522,60
Price per m² calculated area	€	150,05

Flat roof

Thickness, mm	417,70
Energy efficiency index, U, W/m ² K	0,10
Calculation area, m²	35,05

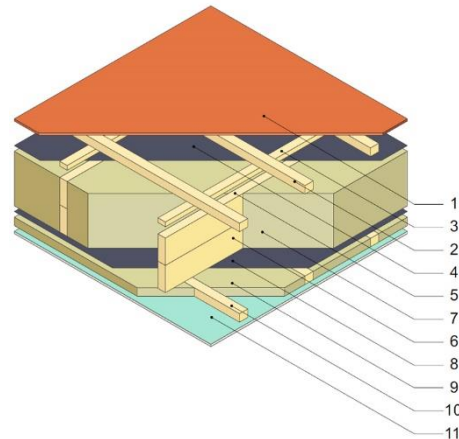
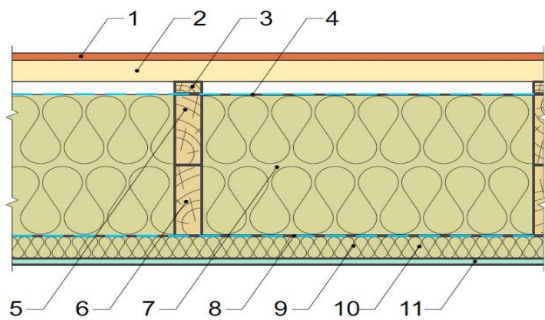

Materials	Thickness, mm	
OSB 3 Egger 15 mm	1	12,00
Lath 45x50 mm	2	45,00
Lath 25x45 mm	3	25,00
Strotex Basix 1300 Super defusion membrane	4	0,10
Beam 45*145 mm C24 CE	5	
Beam 45*145 mm C24 CE	6	
Basalt insulation material IZOVAT, 40 kg/m ³ 100 mm		290,00
Basalt insulation material IZOVAT, 40 kg/m ³ 100 mm	7	
Basalt insulation material IZOVAT, 40 kg/m ³ 100 mm		
SIGA MajRex Vapour barrier	8	0,10
Basalt insulation material IZOVAT, 40 kg/m ³ 50 mm	9	45,00
Lath 45x50 mm	10	
Plasterboard	11	12,50
Total thickness, mm		417,70
Total cost	€	5 783,44
Price per m² calculated area	€	165,03

Windows

Calculation area, m²

66,20



Materials

Rehau Synego window profile (installation in wall panels included)

Profile thickness 80mm (depends on window openings)	€	27 164,55
---	---	-----------

Glazing 4i-16ArTep-4-16ArTep-4i, 44mm Ug=0.57 W/m ² K		
--	--	--

Fittings MACO, G-U		
--------------------	--	--

Alenor sealing tapes	€	1 413,82
----------------------	---	----------

Aluminium window sills	€	743,79
------------------------	---	--------

Automatic window slides, anthracite colour	€	10 179,50
--	---	-----------

Average heat losses of window constructions Uw, W/m ² K 0.68		
---	--	--

Total cost	€	39 501,66
-------------------	----------	------------------

Price per m² calculated area	€	596,70
--	----------	---------------

Facade and roof finishing

Calculated facade area, m ²	448,80
Calculated roof area, m ²	211,81



Materials

Decorative facade plaster	€	10 543,52
Facade paint	€	1 917,00
Ceramic roof tiles (set)	€	7 237,56
Drainage system	€	2 714,08
Total cost	€	22 412,17
